



Hispec[®] HI5000

Downhole Pressure Transmitter



- Compact design
- NACE certified materials
- Silicon-on-sapphire sensor technology for outstanding stability
- High temperature up to 200°C
- High pressures up to 2000 bar
- All-welded and sealed construction for use in harsh and corrosive environments



Vers. 20/1/Eng



Description

The HI5000 transmitter, for downhole applications, is highly compact with a maximum length of 58mm.

The tough, corrosion-resistant design, using NACE certified materials, makes installation easy in challenging environments. The sensor is designed to withstand high shock and vibration inputs in high temperature applications which require accuracy, stability and long term performance of downhole pressure monitoring.

Dimensions (in mm)



ELECTRICAL CONNECTION

PIN	Designation
A	+ Excitation
B	+ Signal
C	- Signal
D	- Excitation
E	RTD
F	RTD

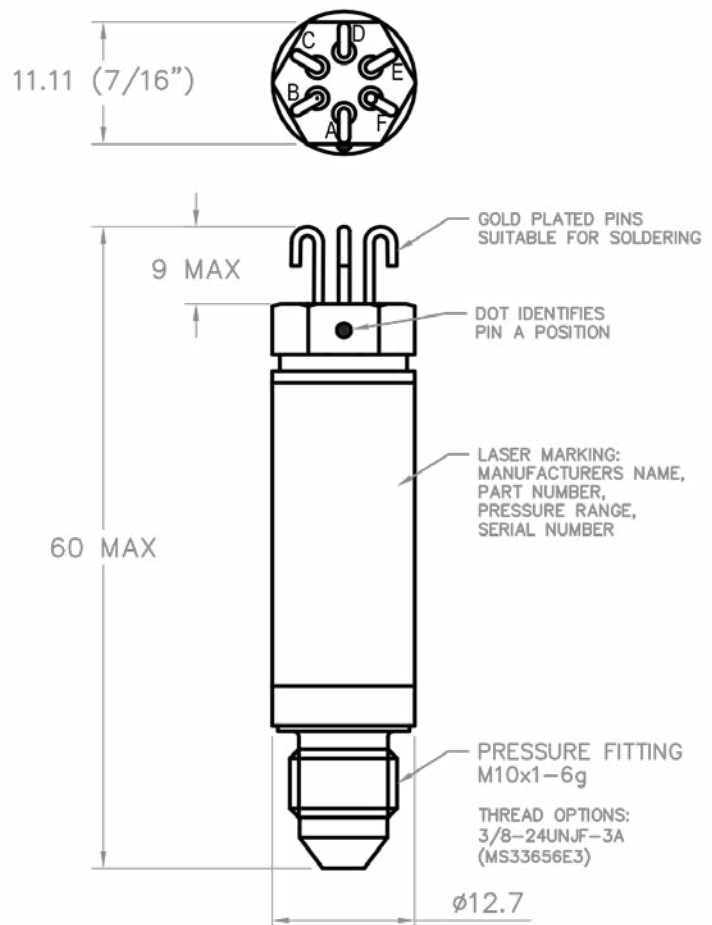

Technical Data

Type	HI5000
Sensor Technology:	Silicon-on-Sapphire
Pressure Range:	See Table 1
Proof Pressure:	See Table 1
Burst Pressure:	See Table 1
Excitation:	3-10 VDC (5 VDC Nominal)
Input Resistance:	4000Ω ±1000Ω
Output Resistance:	4000Ω ±1000Ω
Output at zero pressure over the calibrated pressure range:	±8.0 mV/V
Full scale sensitivity (span) over the calibrated temperature range:	10-20 mV/V Nominal
Operating Temperature Range:	-40°C to +200°C
Calibrated Temperature Range:	+24°C to +180°C
Non-linearity & Hysteresis Combined:	±0.150 % of span maximum (Best Fit Straight Line method)
Total Error Band (Non-linearity, Hysteresis & Thermal Effects):	± 0.20% of span, serial number specific polynomial model P(T,mV) provided for all input pressures and temperatures over the calibration range
Pressure Media:	Any compatible with NACE approved Titanium grade 5 and BT9 alloys (other materials available. Contact sales)
Weight:	20g maximum (less than 1 oz.)
Process Connection Thread:	3/8-24UNJF as per MS33656-E3
Insulation resistance:	All connections pins together to case: 100 MΩ minimum at 50 VDC
Platinum Resistance Temperature Detector (RTD):	0°C, 1000Ω ±0.06% to IEC 751 Class A, Alpha = 0.00385 nominal
Recommended Installation Torque:	125 to 150 in-lb (14-17 Nm)
Calibration Data:	The calibration certificate supplied with each unit includes the coefficients for a 5th order polynomial calibration model

Table 1

MODEL NUMBER	PRESSURE RANGE [BARSG]	PROOF PRESSURE	BURST PRESSURE
HI5000-0400	0-400	200%	300%
HI5000-0600	0-600	200%	300%
HI5000-1000	0-1000	150%	200%
HI5000-1500	0-1500	110%	150%

DISCLAIMER : ESI Technology Ltd operates a policy of continuous product development. We reserve the right to change specification without prior notice. All products manufactured by ESI Technology Ltd are calibrated using precision calibration equipment, traceable to national measurement standards.